

Follow us



HAPPINESS IS A JOURNEY

USER MANUAL

CPX PRO

SAFETY INSTRUCTIONS

To ensure your safety, please read this manual carefully before riding and make sure you are always following the requirements below:

- 1 Fully understand the information in this manual, include but not limited to the relevant instruction, precautions and warnings.
- 2 Fully understand the operation and contingency measures of CPX PRO smart electric vehicle.
- 3 Be Fully aware of warning labels of CPX PRO smart electric vehicle.
- 4 Don't disassemble vehicle or any parts, if need replacement, please contact local dealer.
- 5 Please keep this manual carefully.



All parameters of this vehicle have been permanently set according to the national standard before leaving factory. The company is not responsible, if the original electrical or circuit has changed and caused excess, such as increase the speed.

USER INSTRUCTIONS

To ensure the safety of you and others, please make sure to observe the following matters:

- 1 Don't lend your vehicle to someone who can't operate it in order to prevent any hurts.
- 2 Please comply with local laws and regulations to drive on the road.
- 3 Do not ride after you take medications which may affect your riding ability, drink alcohol, or when you are unwell.

USER INSTRUCTIONS

- 4** Observe traffic regulations and traffic signs, according to the provisions of laws and regulations to carry man and cargo. Confirm the surrounding road conditions and vehicle condition any time, so as to actively avoid danger.
- 5** In rainy and snowy weather, braking distance will be extended, please slow down, Avoid travelling in bad weather such as storms and typhoons.
- 6** Wear safety equipment, such as helmet, and appropriate protective clothing if necessary, such as gloves and mask.
- 7** To ensure the safety of you and others, please avoid using the high beam under good lighting conditions. Continuous use of the high beam will cause visual obstacles to the opposite vehicles and pedestrians and affect the safe driving
- 8** Please turn off the power and remove the key immediately after use. Do not allow children to play, so as to avoid loss to your family and property.
- 9** Perform a basic check each time before riding, and regularly go to VMOTO Service Center for maintenance.
- 10** Check before riding. If there is any abnormality, please timely carry out maintenance or seek professional maintenance.
 - a.** Check the status of power circuit, lighting circuit, etc.
 - b.** Check whether the front and rear brakes work normally.
 - c.** Check fixing of handlebars、 front and rear wheels
 - d.** Check tire pressure.



All pictures in this manual are for reference only, please refer to the actual product. The pictures in the manual are based on the VMOTO electric vehicle CPX PRO, please refer to the bikes for details.

The actual product function may differ from the manual content due to technical upgrades, firmware updates or other changes. For the latest function introduction and safe use guide information, please download VMOTO APP, and refer to the embedded electronic manual: or visit the official website of VMOTO: www.vmoto.com

QUICK START

-01-

Check Accessories Items



× 2

Remote controls



× 1

Rear view mirrors



× 1

User manual



× 2

Keys



× 1

Spanner for mirrors



× 1

Charger



× 4

I-shaped rubbers



× 4

Hexagon bolts



× 1

Front windshield

- 02 -

Assemble Parts

Assemble the front windshield second

Assemble the rear view mirrors first. Assemble the front windshield second. Assemble front windshield, tighten screw in A position. Assemble and tighten screws as the numbers on picture.

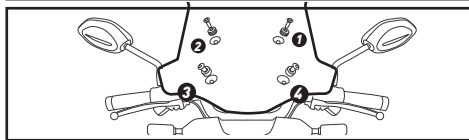
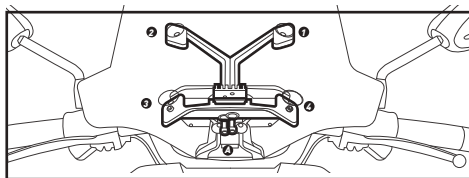
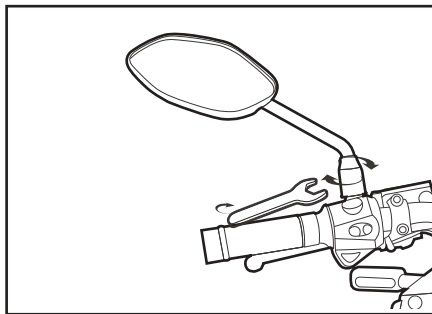

QUICK START

- 03 -

Install Battery Pack



1 Open battery compartment under the seat and remove the segregation board.

2 Put in the battery pack.

3 Plug-in the main connector(marked 1), make sure the battery buckle(marked 2) must be fastened properly before riding

4 Put the segregation board back and put down the seat.

QUICK START

- 04 - Quick Start

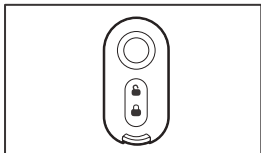

- 1** Press 'UNLOCK' on remote control.

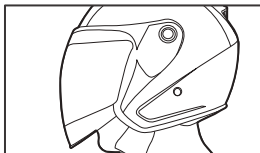

- 2** Wear helmet.

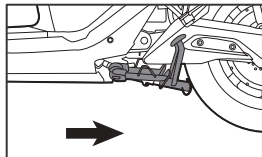

- 3** Ride on CPX PRO, kick side stand and main stand out.

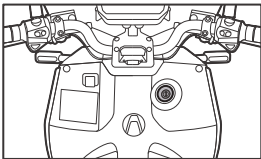

- 4** Press 'Power' on remote control or turn the key to ignition switch "On" position, power on

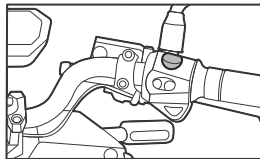

- 5** Press 'Parking' button, unparking CPX PRO, parking symbol off, READY light on.

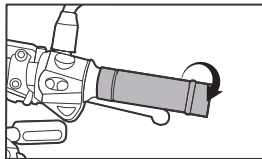

- 6** Turn accelerator gently, CPX PRO run.

Download APP

**CPX PRO has GPRS function, can connect with your smart phone.
By APP, you can use smart phone to manage and query your CPX PRO.**

Only IOS and Android are currently available now, please confirm your smart phone operating system in advance.

IOS system: APP only supports Apple IOS 9.0 system and above.

Android system: APP only supports Android 4.4 system and above.

Download and install the VMOTO APP by QR code on page in this manual.



VMOTO APP

From the date of purchase of the vehicle, you will automatically receive a free two-year central control SIM card data in order to use the VMOTO electric APP function. Please be sure to complete the next year's data recharge before the end of the two-year free period. If the recharge is not overdue, the operator will automatically close the recharge interface, the flow recharge function cannot be restored, and the VMOTO electric vehicle APP cannot be used normally.

CONTENTS

DESCRIPTION OF COMPONENTS AND PARTS	09
OPERATION GUIDE	13
RIDING GUIDE	18
BATTERY USE INSTRUCTION	21
APP INSTRUCTION	24
MAINTENANCE	26
COMMON PROBLEMS AND TROUBLESHOOTING METHODS	28
CHECK LIST	33

DESCRIPTION OF COMPONENTS AND PARTS

a. Schematic diagram of components and parts

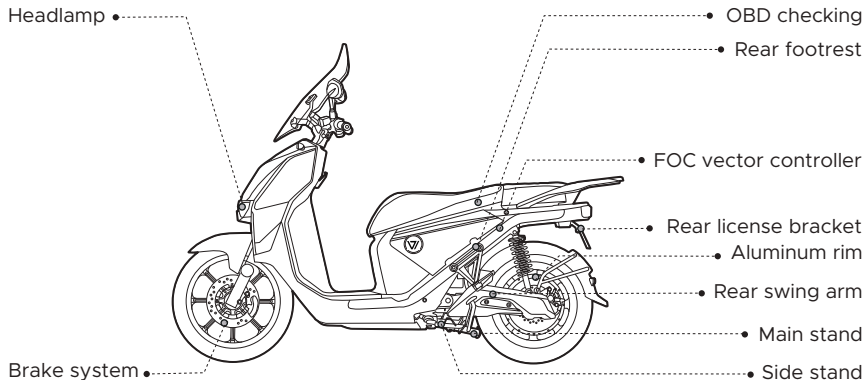

SIDE VIEW

DESCRIPTION OF COMPONENTS AND PARTS

a. Schematic diagram of components and parts

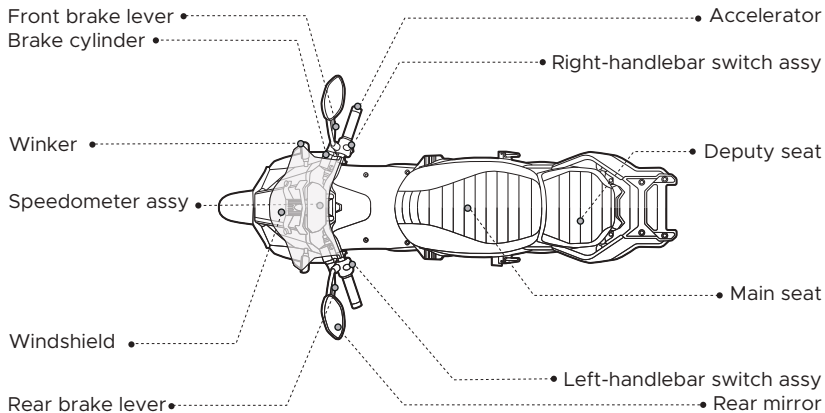

TOP VIEW

DESCRIPTION OF COMPONENTS AND PARTS

b. Schematic Diagram Of The Speedometer

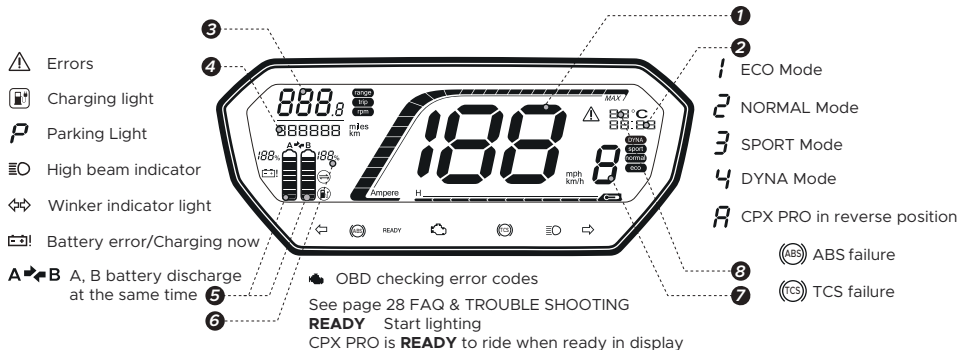

1 Speed

Display current speed

2 Time

Display current time

3 Endurance Mileage

Display current endurance mileage

4 Total mileage

Display the total mileage

5 Power display bar

Display current A、 B battery power

6 Battery percentage display

Display current A、 B battery power percentage

(When work with two battery, battery percentage display the higher battery)

7 Gear display/Forward,reverse status display

Display current gear/Forward,reverse status.

8 Controller temperature

Display current controller temperature

DESCRIPTION OF COMPONENTS AND PARTS

b. Schematic Diagram Of The Speedometer

RANGE Remaining distance per charge. RPM Current rotating speed.

TRIP Current riding distance.

TURN ON SWITCHING ADJUSTMENT MODE

1. Press the high beam switch for 3 times

(i.e., the high beam indicator flashes for 3 times) in continuous time such as 4 seconds;

2. At this time, the current display mode

(driving range/ single mileage/ revolving speed) is flashing, indicating that the motor has entered the adjustment mode;

DISPLAY SWITCHING (DRIVING RANGE / SINGLE MILEAGE / REVOLVING SPEED)

Turn on switching adjustment mode, and turn on or off the high beam switch to toggle the display mode (driving range / single mileage / revolving speed) once. Cycle the switching in this way.

REMOVE SINGLE MILEAGE

If not in trip state; debug to single mileage state (trip), Turn on and off the high beam 6 times within 4 seconds, at which time the instrument's single mileage returns to zero.

SWITCH THE DISPLAY UNIT (KM AND MILE, KM/H AND MPH)

Retract the side stand, and enable the switching adjustment mode. Toggle the "parking brake handle switch" from OFF (P gear indicator on) to ON (in 2 seconds), and then to OFF, thus switching the display units (km and mile, km/h and mph); toggle the "parking brake handle witch" from OFF to ON (in more than 2 seconds), and then to OFF, thus turning on the LCD backlight. (Remarks: now the brightness is fixed at the brightest level).

OPERATION GUIDE

a. Left Switch

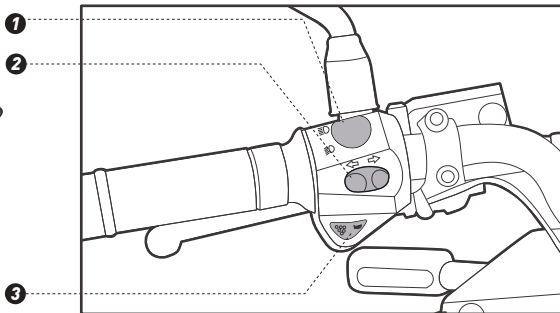
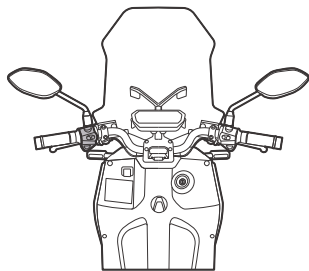

1 High/low beam switch

Up position, high beam on;
Down position, low beam on.

2 Winker switch

Turn to left, left winker on;
Turn to right, right winker on.

3 Horn switch

Press, horn on; release, horn off.

OPERATION GUIDE

b. Right Switch

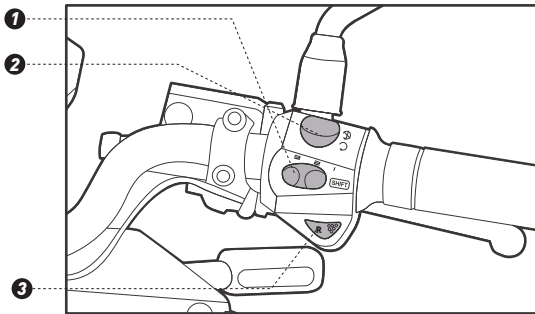
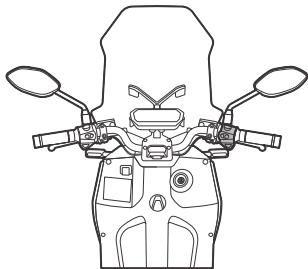

1 Mode switch

CPX PRO is set with 3 modes: 1:ECO mode 2: NORMAL mode 3: SPORT mode. Position at left, mode 1; position in the middle, mode 2; position at right, mode 3.

2 Parking switch

Press the parking switch up,CPX PRO at parking position,parking indicator (P) light on;press the parking switch down display (READY),CPX PRO at unparking status.

3 Forward reverse switch

Gently press two times forward reverse switch R,display mode number change to "F",CPX PRO is ready to move forward,turn accelerator gently,CPX PRO can drive forward;press again,CPX PRO in reverse position,keep pressing 'R' button,turn accelerator gently,CPX PRO can move backward;press again,display show mode number as normal,CPX PRO in normal driving position.

OPERATION GUIDE

c. Remote Control

CPX PRO use second generation smart remote control, within 50 meter radius, press the button, can lock or unlock your CPX PRO.

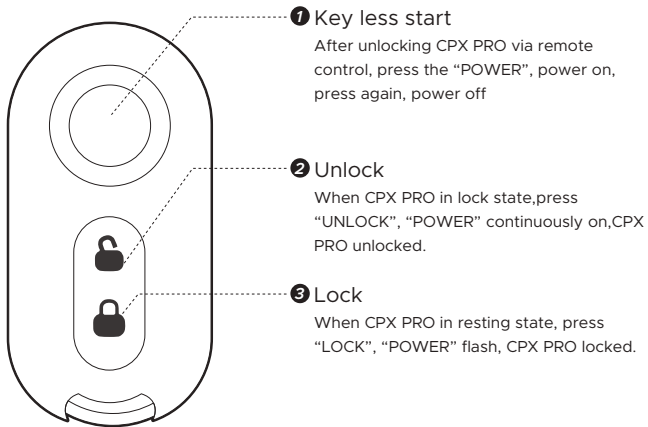

OPERATION GUIDE

d. Mechanical Key



1. Mechanical key start

After unlocking CPX PRO via remote control, turn the key to "ON" position, power on, turn the key back to "OFF" position, power off.



3. Open storage & seat

Put key in storage&seat lock, turn key to right direction, when hear sound "click", storage&seat open. Press "unlock" 3s via remote control, when hear sound "click", storage&seat open.

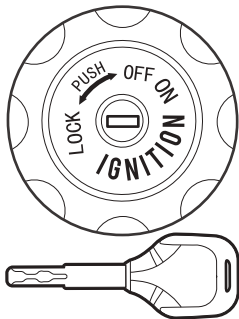
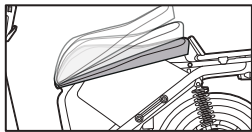

2. Handlebar lock

1. CPX PRO in parking position, turn handlebar to the extreme left position, put key in handlebar lock, and turn the key to right position, handlebar locked.

2. Put the key in handlebar lock, turn the key to left position, handlebar unlocked.

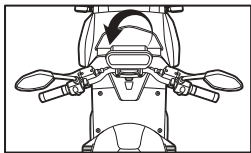

Put in the key and press then turn left



Put the key in then turn left

OPERATION GUIDE

e. Circuit Protector Switch Operate

As the protection switch for the main power of CPX PRO smart electric vehicle, the circuit protector will automatically disconnect to ensure safety when the vehicle circuit is abnormal or the current caused by short circuit exceeds the set safe value.

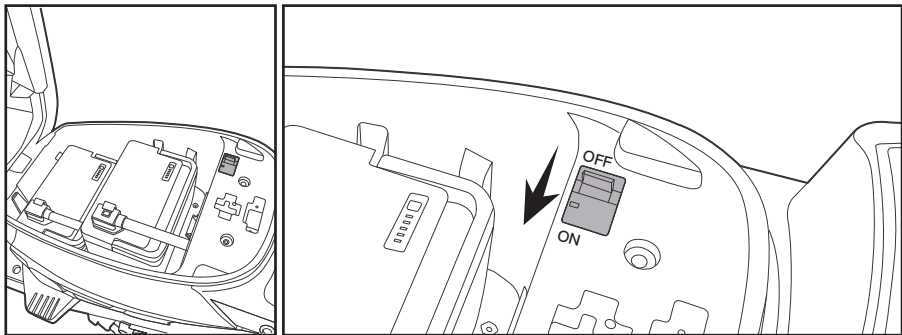

TIPS: In order to protect your safety, please turn off the circuit protector switch when cleaning, storing the vehicle for a long time, or removing the battery.

RIDING GUIDE

a. Checking List Before Riding

Make sure to check the following items before riding a CPX PRO smart electric vehicle, which will guarantee your safety on the road.

- 1 Whether the handlebar is stable and flexible when turning.
- 2 Whether the switches on the right and left handlebars can work correct.
- 3 Whether the throttle working properly.
- 4 Make sure the tyre pressure is ok. The suggested tire pressure is 175Kpa for front wheel, 200Kpa for rear wheel with rider only; 225Kpa for rear wheel with 1 rider and 1 passenger.
- 5 Check tire surface, make sure no cracks, damage, and foreign matter puncture or attachment.
- 6 Whether the tread depth is sufficient. If the tire is worn to the black shadow mark in the picture, it needs to be replaced.
- 7 Whether any error warning light on the display when power on.
- 8 Whether the battery capacity is sufficient for your trip.
- 9 Whether all lights working properly.
- 10 Whether the horn working properly.
- 11 Whether the mirrors are clean. Adjust them to the proper angle.
- 12 Whether the brake oil is sufficient, whether the brake lever and brake system working properly.

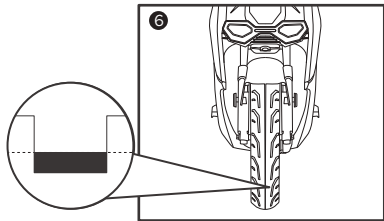

Any exceptions or operational doubts, please contact VMOTO official dealer's service center.

RIDING GUIDE

b. Start The Vehicle

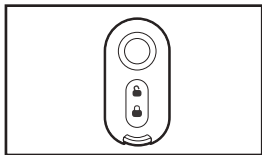

- 1** Press “UNLOCK” on remote control

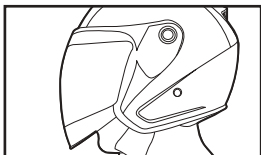

- 2** Put on helmet.

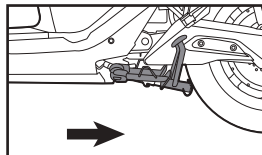

- 3** Riding CPX PRO, kick out side stand.

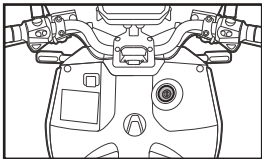

- 4** Press “POWER” or turn the key to on position in ignition switch, power on

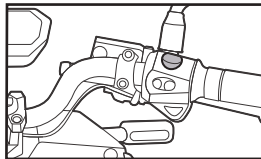

- 5** Press 'Parking' button, unparking CPX PRO, parking symbol off, READY light on.

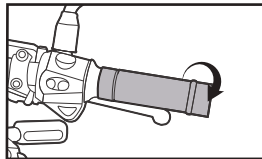

- 6** Turn throttle gently, CPX PRO run

RIDING GUIDE

TIPS:

- ➊ Before riding, make sure side stand and main stand is kicked out, handlebar is unlocked.
- ➋ DON'T press "PARKING" during riding, in case any dangerous due to motor power off and in parking status. DON'T put side stand at standing position, in case any dangerous due to motor power off and in standing status.
- ➌ CPX PRO need to power on under steady standing status. In case any unusual situation, please move the vehicle to side of the road, in case any dangerous, please don't restart the vehicle when it still running or in the middle of the road.

c. Riding Precautions

- ➊ After the riding start, it should accelerate slowly to avoid excessive starting current caused by instantaneous rapid acceleration and increase energy consumption.
- ➋ Under the premise of ensuring safety, try to keep a constant speed on the way you are driving, reduce frequent starts, brake, instant acceleration, etc.
- ➌ The maximum load of CPX PRO is 180KG(35KG for rear shelf). Overload is strictly prohibited.
- ➍ When push vehicle moving forward manually, please press "parking" button, in order to prevent accidents caused by sudden start of the vehicle due to unintentional turning of the throttle.
- ➎ Please turn off the power while parking and remove the key.

BATTERY USE INSTRUCTION

a. Charging On-board

- ➊ Insert the main charger plug into the charging port of the vehicle.
- ➋ Insert the charger's AC power plug into the socket, and the battery starts charging when the charger indicator turns red.
- ➌ The battery is fully charged if the charger indicator turns from red to green

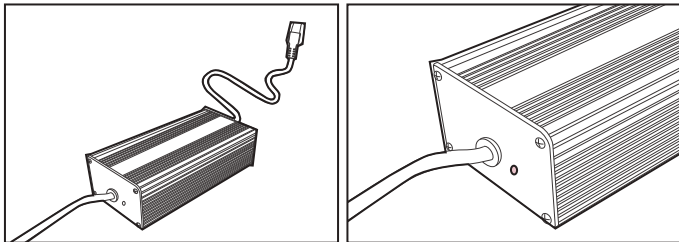

Battery level display

Charging: red light is on continuously

Full: green light on continuously

Fault: red and green light flash alternately

BATTERY USE INSTRUCTION

b. External Charging

- 1 Open the seat, switch off circuit protector, take out storage cover.
- 2 Disconnect the power plug, take out the battery from vehicle.
- 3 Connect charger with battery, then connect charger with power supply, charger working, red light keeps on.
- 4 If only use one battery, please cover the connector cover with another main connector.

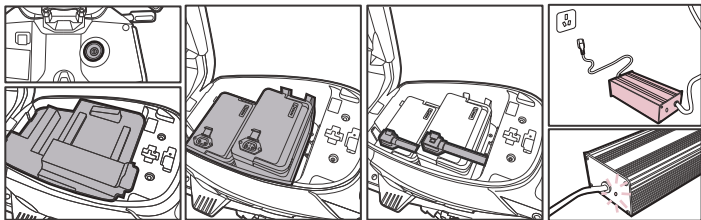

TIPS:

- Keep battery pack away from water;
- Charging temperature: 0-40°C, discharging temperature: -15°C-45°C;
- Charging battery pack after using, if don't use the vehicle for long time, must take out battery pack from vehicle.
- Forbidden to short circuit positive and negative pole at battery pack input and output position.
- Forbidden to children touch the battery pack and put the battery pack into fire;
- Forbidden to strong impact and press on battery pack;
- Must use official charger, forbidden to use any other charger to charge battery pack;
- Before delivery, battery pack already passed quality checking, forbidden to open the battery pack;

BATTERY USE INSTRUCTION

c. Storage, Maintenance And Transportation

- 1 Please charge the battery to half-saturation state when storing or transporting it (after the battery is discharged, charge it for 3 hours). Disconnect the battery to the vehicle to prevent the battery from over-discharging, place it in a dry and ventilated place, and charge it with a charge for 2 hours each 3 months.
- 2 The battery and charger should be stored in a clean, dry, ventilated place, avoid contact with corrosive substances, and keep away from power, fire and heat sources.
- 3 Battery pack storage conditions: ambient temperature $25 \pm 3^{\circ}\text{C}$, ambient humidity $\leq 65\% \text{RH}$.
- 4 To avoid electric shock, please cover the rubber cover of the empty battery plug when using a single battery!

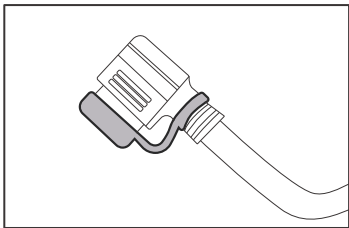

If you encounter any problems, please contact the after sales service or dealer.

APP INSTRUCTION

CPX PRO smart electric vehicle has GPRS communication, GPS positioning and other functions, and can be connected with your smart phone. Through the VMOTO Electric Vehicle APP, you can use your smart phone to manage and query your vehicle.

*Some functions require the use of wireless networks and positioning functions, please be aware.

The current mainstream mobile phone system versions are iOS and Android operating systems, please confirm the operating system specifications of the smart phone before installation.

Main functions of VMOTO Electric Vehicle APP (Available subject to different countries)

- ① Vehicle condition diagnosis: when the vehicle is started, a one-key physical examination, real-time understanding of vehicle health status;
- ② Multiple anti-theft: When the vehicle is illegally displaced, the vehicle body will issue an alarm, and the APP will notify the user as soon as possible and track the vehicle location in real time;
- ③ Data recording: Users can learn about vehicle information, remaining power, mileage, riding trajectory and other information through the APP;
- ④ Riding appointments with riders: Through the APP, users can start mobile social interaction, realize communication between people in a new way, and enjoy the fun of online and offline riding.

APP INSTRUCTION

CPX PRO smart electric vehicle has GPRS communications, GPS locate and other functions which can be connect to your smart phone. You can manage your vehicle, query and do other operations by VMOTO APP



Download APP



Bind APP

PASTE
BARCODE

Only iOS and Android are currently available now, please confirm your smart phone operating system in advance.

iOS system:APP only supports Apple iOS 9.0 system and above.

Android system: APP only supports Android 4.4 system and above.

The functions of VMOTO Electric Vehicle APP may vary with version updates, function upgrades and different vehicle types. Please refer to the actual content of the latest version.

MAINTENANCE

Regular maintenance can improve the service life and driving safety of TC PRO smart electric vehicle. We suggest you follow the following advice to take care of your vehicle.

a. Regular Overhaul And Maintenance

We recommend that after the initial inspection and maintenance of the new vehicle at the VMOTO Authorized Service Center 1,000 km or 3 months after the purchase of the new vehicle (based on the first arrival parameter). It is recommend that you do it every 3,000KM or 6 months (based on the first arrival parameter) for regular inspection and maintenance. VMOTO Authorized Service Center will provide maintenance services for your vehicle (maintenance services may involve fees, please refer to the service center staff or official customer service staff).

TIPS:

The maintenance provided by VMOTO Authorized Service Center is free of charge, which can be did by yourself or at a regular electric vehicle repair shop

b. Daily Cleaning And Maintenance

- Cleaning: Please use clean water, neutral detergent, soft cloth and sponge to clean the surface of the vehicle; Do not use metal brush, sandpaper, etc. to wipe the body, so as not to scratch the body and parts. On the surface. After cleaning, wipe the vehicle dry with a soft dry cloth.
- Storage: Please park the vehicle in a dry and cool room to reduce sun exposure and rain, in order to avoid corrosion of parts and shorten the service life.

MAINTENANCE

c. Warning

- 1 Please switch off the circuit protector switch before cleaning.
- 2 Do not use strong pressure water to wash it directly, in order to prevent internal electrical components and lines from intruding or soaking water and causing vehicle mechanical failures or other hidden dangers of accidents.
- 3 In case don't use for long time, please turn off circuit protector switch and disconnect the battery from vehicle; prevent over discharging, please recharge the battery 2 hours each 3 months.
- 4 After long-term storage, please fully charge it before use.

COMMON PROBLEMS AND TROUBLESHOOTING METHODS

α. FAQ & Troubleshooting

Error	Causes	Solutions
The vehicle has no electricity, and the start button does not shine	<ol style="list-style-type: none">1. Battery is poorly connected2. Circuit protector switch is not turned on	<ol style="list-style-type: none">1. Connect the power cable appropriately2. Turn on the circuit protector switch
Power on, turning accelerator, motor not run	<ol style="list-style-type: none">1. Low battery power2. Side stand is on3. At parking mode4. Brake lever does not reach the right position5. Accelerator error6. The controller plug is loose7. Controller error	<ol style="list-style-type: none">1. Charge the battery2. Kick the side stand out3. Press parking button4. Place the brake lever at the right position5. Change accelerator6. Re-plug controller7. Change controller
Speed is too slow or mileage is too short	<ol style="list-style-type: none">1. Low battery power2. Flat Tyre3. Heavily overloaded4. Brake pads need to be replaced5. Battery aging or normal scrap	<ol style="list-style-type: none">1. Charge the battery2. Pump up the tyre, check tyre pressure before riding3. Foster a good habit, keep an appropriate load4. Change the brake pads and check the brake system before riding5. Change the battery
Battery cannot be charged	<ol style="list-style-type: none">1. Poor contact of charger plug2. Used wrong charger3. Battery aging or normal scrap	<ol style="list-style-type: none">1. Check whether the battery plug is at right position or not2. Use VMOTO charger3. Change the battery

COMMON PROBLEMS AND TROUBLESHOOTING METHODS

Error	Causes	Solutions
Error 99 on speedometer	Controller communication error	Please contact after sales service or dealer
Error 98 on speedometer	Controller stop working(Possible over current,motor blocking, under voltage,over temperature)	Please stop riding and wait for a while then restart or contact after sales service or dealer
Error 97 on speedometer	Controller power tube error	Please contact after sales service or dealer
Error 96 on speedometer	Controller hall sensor error	Please contact after sales service or dealer
Error 95 on speedometer	Accelerator error	Please check the accelerator plug or contact after sales service or dealer
Error 94 on speedometer	Battery communication error	Please check the battery plug or contact after sales service or dealer
Error 93 on speedometer	Charging, over current error	Please stop charging and check the charger
Error 92 on speedometer	Charging, over voltage error	Please stop charging and check the charger
Error 91 on speedometer	Battery over temperature error	Please stop riding or charging and wait for a while

COMMON PROBLEMS AND TROUBLESHOOTING METHODS

Error	Causes	Solutions
Error 90 on speedometer	Battery discharging over current error	Please stop riding if keep showing and contact after sales service or dealer
Error 89 on speedometer	Battery charging low temperature error	Please move the vehicle to warm indoor place and wait for a while
Error 88 on speedometer	Battery discharging low temperature	Please move the vehicle to warm indoor place and wait for a while
Error 87 on speedometer	Network connection error	Please move the vehicle to open area and wait for a while or contact after sales service or dealer
Error 86 on speedometer	GPS connection error	Please move the vehicle to open area and wait for a while or contact after sales service or dealer

COMMON PROBLEMS AND TROUBLESHOOTING METHODS

b. Battery Troubleshooting

Status	Errors	Causes	Solutions
Before using	Battery runs out, unable to activate the vehicle	Battery no power	Please charge the battery
In Operation	In battery low power mode. Battery below 10% ,vehicle power-off	Battery runs out, low-voltage protection	Please charge the battery
In Operation	Display 88 Error code	Battery discharging low temperature	Please move the vehicle to warm indoor place and wait for a while
In Operation	Display 90 error code	Battery discharging over current error	Please stop riding if keep showing and contact after sales service or dealer
In operation	Display 91 error code	Battery over temperature error	Please stop riding or charging and wait for a while
In Operation	Display 94 error code	Battery communication error	Please check the battery plug or contact after sales service or dealer
In Operation	Display power reduce, over night or the next day.	ECU, controller and alarm components take power from battery automatically, normal phenomena.	Normal use
In Operation	Mileage different from the official announced	Official announced mileage is tested under specific circumstances and states. Affected by different road condition, weather, temperature, wind resistance, loading ect.	Any questions, please contact after sales service or dealer

COMMON PROBLEMS AND TROUBLESHOOTING METHODS

Status	Errors	Causes	Solutions
Storage	Press "Start" , no power	The battery is stored too long time, battery runs out	Please charge the battery. If it is not possible to charge, please contact after sales service or dealer
In Charge	Display 89 error code	Charging at low temperature	Please charge the battery in room temperature.
In Charge	Display 92 error code	Charging overtag	Stop charging the battery, check the charger
In Charge	The charger gets hot during charging	In the charging process, the internal current of the charger is too high, produce large amount of heat. The metal shell can effectively dissipate heat, which will lead to the high temperature of the shell	Please use normally, charge in dry and ventilated place
Battery water penetration	The battery is not working properly, unable to start the vehicle.	Vehicle in the rain, in the water, wading across deep causing battery flood.	Please stop using, contact after sales service or dealer
Battery box broken	Battery shell broken caused by clash or dorp from high place.	Battery shell broken	Please stop using, contact after sales service or dealer

CHECK LIST	1000 KM 3months	3000KM 6months	6000KM 12months	9000KM 18months	12000 KM 24months	15000 KM 30months	18000 KM 36months	21000 KM 42months	24000KM 48months	Torque (N·m)
Brake fluid	<input type="radio"/>		<input type="radio"/>							
Tire pressure and wear	<input type="radio"/>	<input type="radio"/>	<input type="radio"/>	<input type="radio"/>		<input type="radio"/>		<input type="radio"/>		"FR 175 KPa RR 225 KPa"
Front and rear lining pad wear		<input type="radio"/>	<input type="radio"/>	<input type="radio"/>		<input type="radio"/>		<input type="radio"/>		
Front and rear brake disc wear			<input type="radio"/>							
Fasten front axle nut and rear wheel bolt	<input type="radio"/>		<input type="radio"/>							59
Fasten the swingarm nut	<input type="radio"/>		<input type="radio"/>							59
The motor and the motor retainer bolt fastening nut	<input type="radio"/>		<input type="radio"/>							80
Fasten Front and rear shock bolt fastening	<input type="radio"/>		<input type="radio"/>		<input checked="" type="radio"/>		<input checked="" type="radio"/>		<input checked="" type="radio"/>	F.Upper 22/ F.Lower 32/R45
Steering column locking nut										74
Fasten front caliper bracket (coated glue thread)	<input type="radio"/>		<input type="radio"/>							26
Fasten front brake disc (coated glue thread)	<input type="radio"/>		<input type="radio"/>							42
Fasten rear caliper bracket (coated glue thread)	<input type="radio"/>		<input type="radio"/>							26
Fasten rear brake disc (coated glue thread)	<input type="radio"/>		<input type="radio"/>							42
Battery	<input type="radio"/>	<input type="radio"/>	<input type="radio"/>	<input type="radio"/>		<input type="radio"/>		<input type="radio"/>		

Note: Check the lithium battery balance by BMS reading and manual measurement.

MAINTENANCE RECORD:

Content:

Date:

MAINTENANCE RECORD:

Content:

Date:

MAINTENANCE RECORD:

Content:

Date:

MAINTENANCE RECORD:

Content:

Date:

MAINTENANCE RECORD:

Content:

Date:

MAINTENANCE RECORD:

Content:

Date: